

Air sealing key points

1. Building envelope plate and wall plumbing and electrical penetrations
2. Tub/shower on outside or attic wall
3. Window and door rough openings
4. Airtight, IC-rated recessed lights and electrical fixtures exposed to attic
5. Exterior wall exhaust fan terminations
6. Ceiling mounted bath fans, speakers, etc.
7. Bottom plate and top plate
8. Seams between rigid exterior sheathing
9. Band area between floors, conditioned space and attic
10. Tub on exterior wall
11. Mechanical equipment and ductwork chases in attics, crawlspaces
12. Ceiling/crawlspace electrical boxes
13. Ceiling/crawlspace HVAC boots
14. Shower and tub drain line
15. Fireplace inserts
16. Attic kneewall doors
17. Joist cavities under attic kneewalls
18. Transition between ceiling heights (e.g., 10' to 8')
19. Attic scuttle hole
20. Attic pull-down stairs
21. Wall penetrations of mechanical combustion closets
22. Thresholds at mechanical combustion closet doors
23. Band joist exposed to exterior
24. Band area exposed to unconditioned space (such as basement or garage)
25. Exterior wall penetrations for refrigeration lines, condensate line, etc.

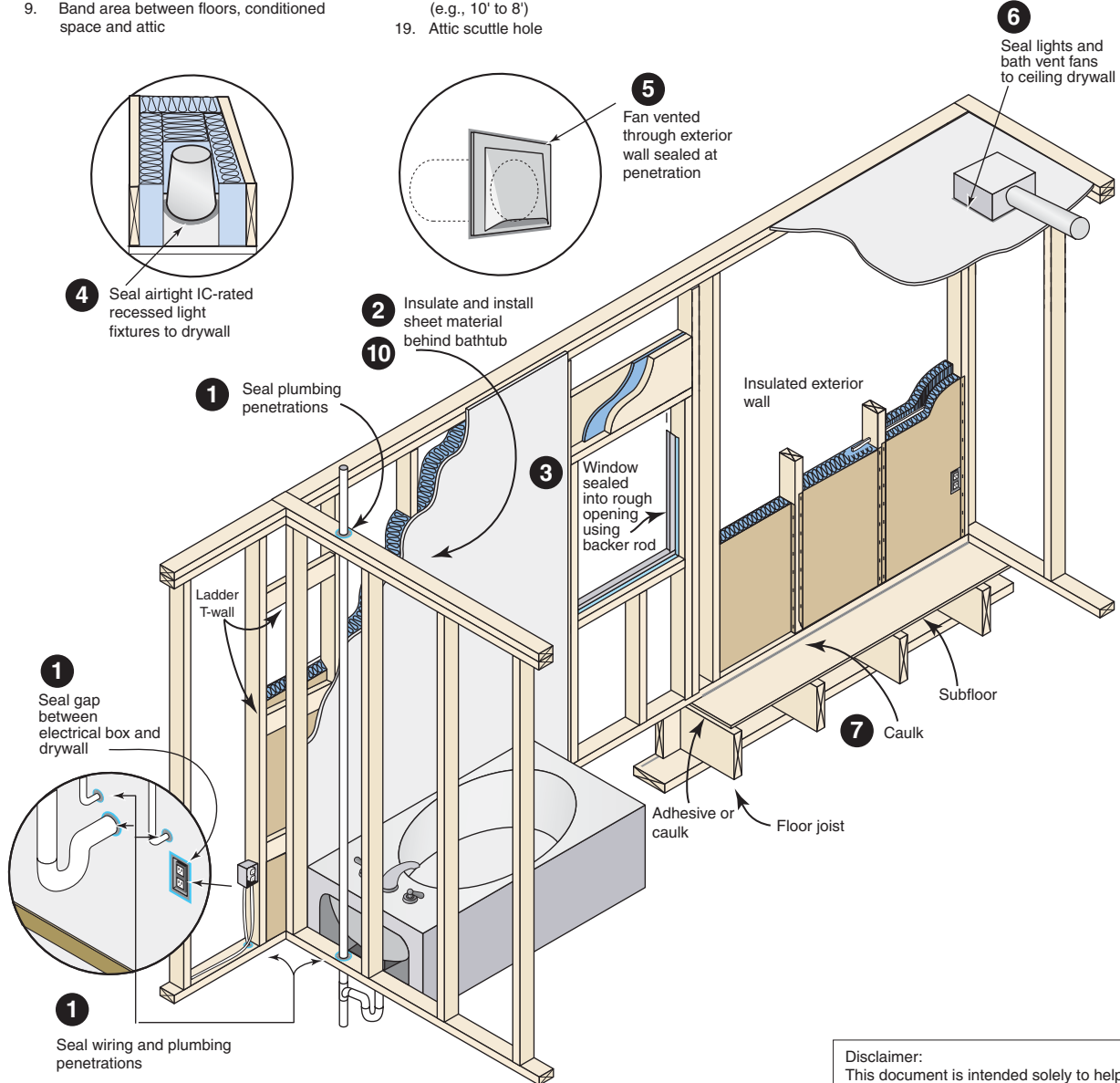

Disclaimer:
This document is intended solely to help graphically demonstrate the air leakage provisions of section 402.4 of the 2006 IECC. It does not cover all airsealing locations or techniques. Other code provisions may be applicable as well.

Air sealing key points *continued*

Chases and common by-passes

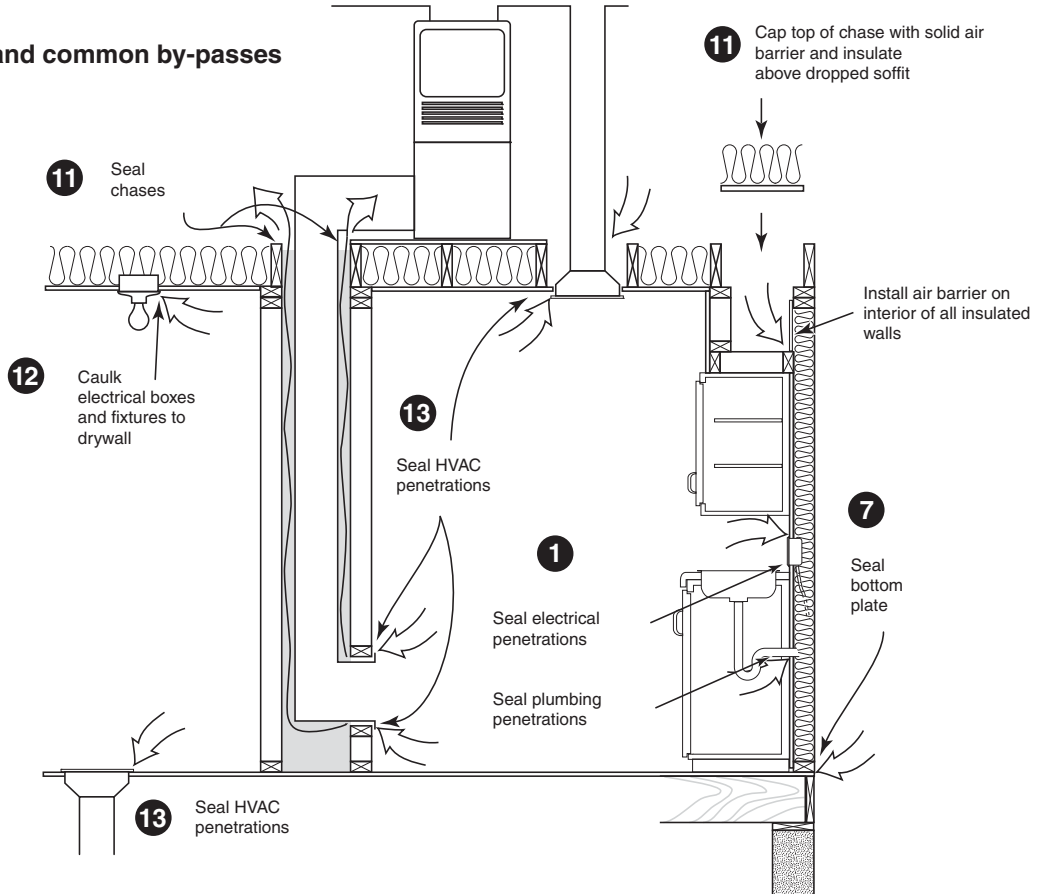

Shower/tub drain rough opening

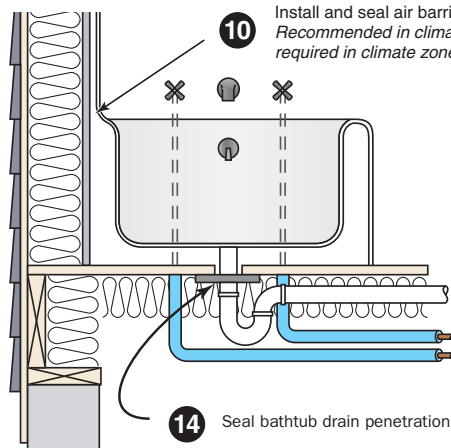

Disclaimer:
This document is intended solely to help graphically demonstrate the air leakage provisions of section 402.4 of the 2006 IECC. It does not cover all airsealing locations or techniques. Other code provisions may be applicable as well.

Air sealing key points *continued*

Window rough opening

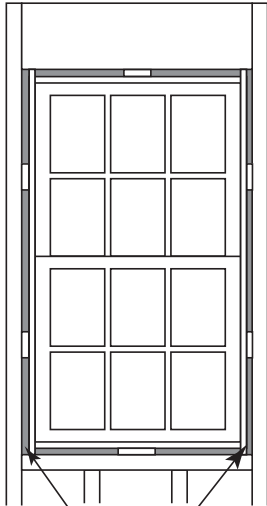

2

Use backer rod or spray foam (appropriate for windows) to fill gaps between window/door and rough opening

Wall cross-section

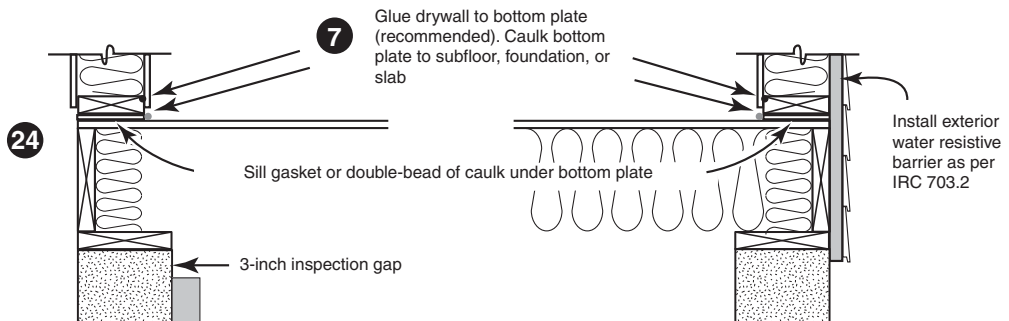
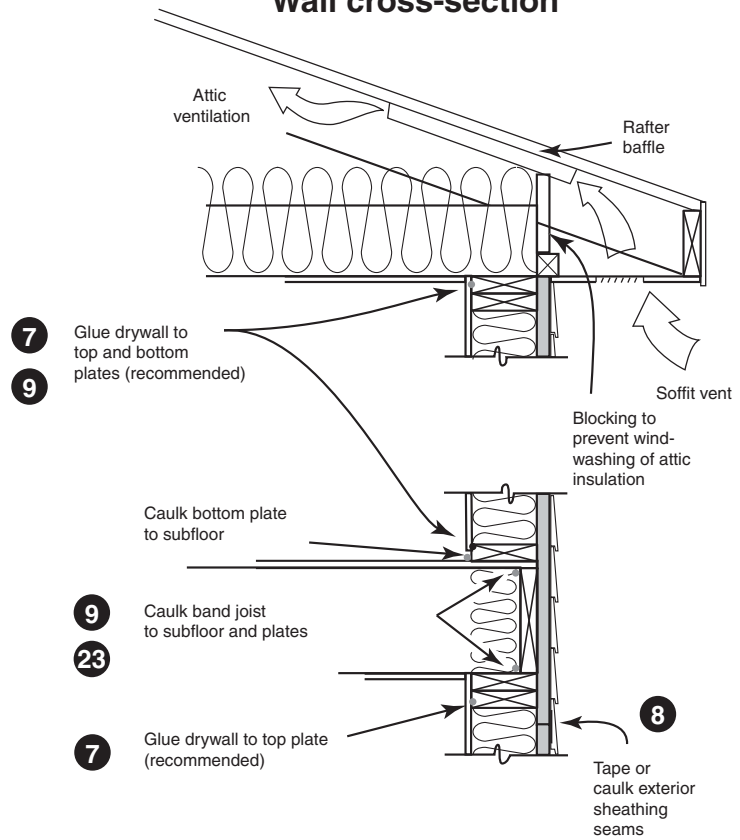

Disclaimer:
This document is intended solely to help graphically demonstrate the air leakage provisions of section 402.4 of the 2006 IECC. It does not cover all airsealing locations or techniques. Other code provisions may be applicable as well.

Air sealing key points *continued*

Combustion chase penetrations

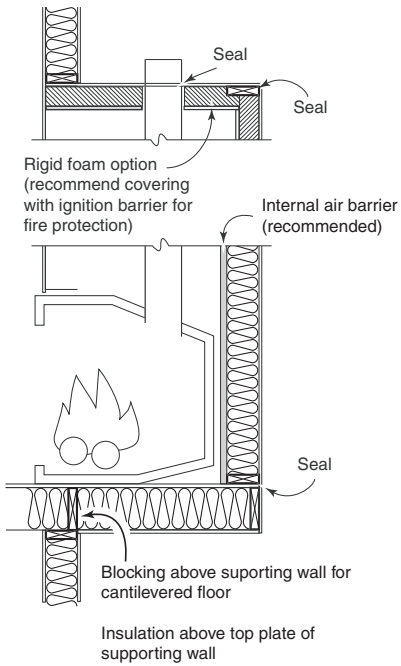

- 15** Seal around chimney flues with sheet metal cap

Exterior penetrations

- 25** Caulk exterior wall penetrations for refrigeration lines, condensate line, etc.

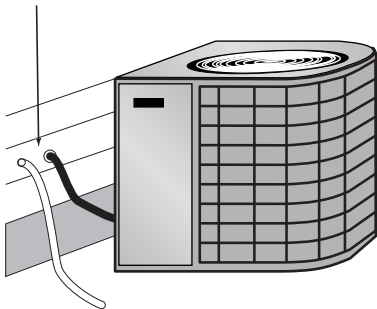

Combustion closet

Combustion air inlets
as per mechanical
and/or fuel gas code

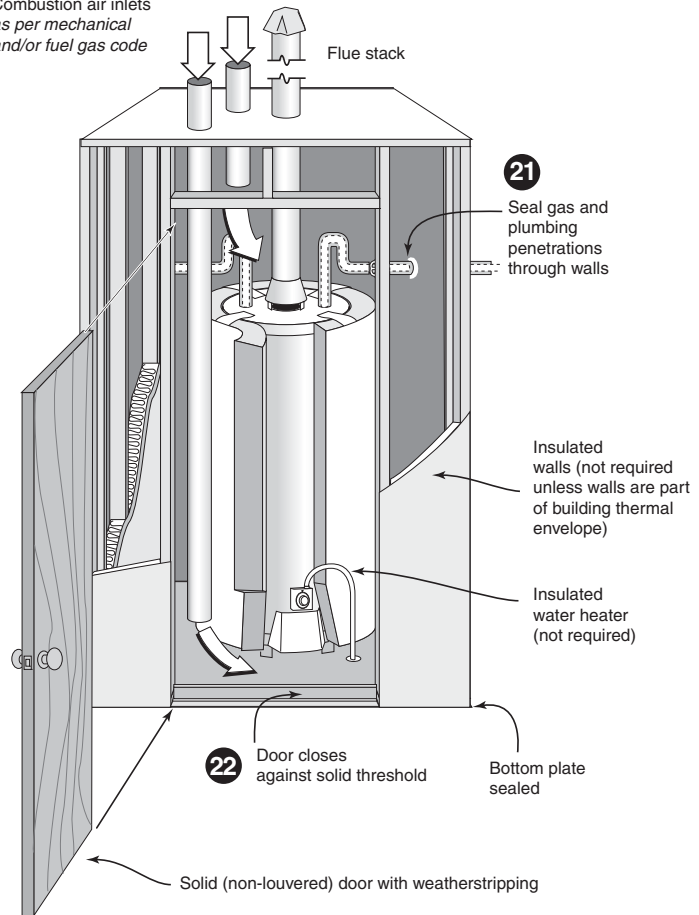

Disclaimer:
This document is intended solely to help graphically demonstrate the air leakage provisions of section 402.4 of the 2006 IECC. It does not cover all airsealing locations or techniques. Other code provisions may be applicable as well.

Air sealing key points *continued*

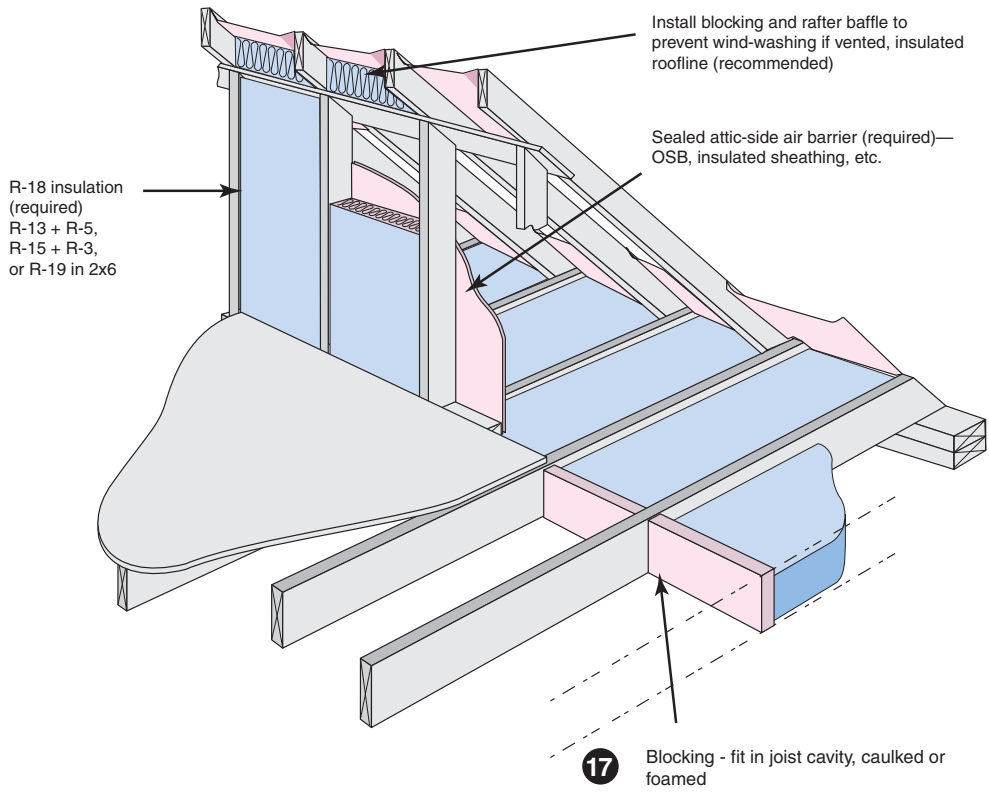

Attic knee-walls

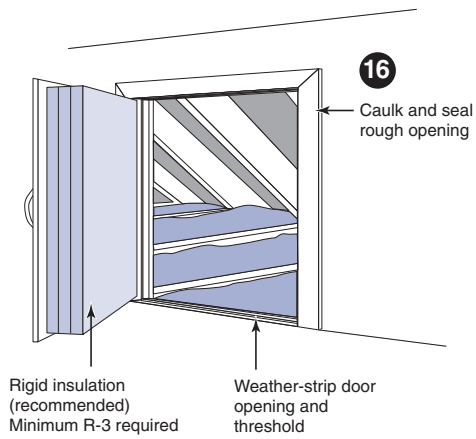

Two-level attic

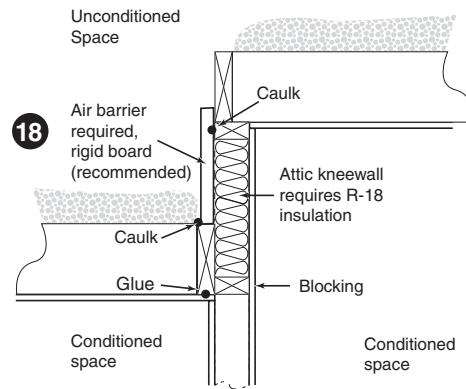

Disclaimer:
This document is intended solely to help graphically demonstrate the air leakage provisions of section 402.4 of the 2006 IECC. It does not cover all airsealing locations or techniques. Other code provisions may be applicable as well.

Air sealing key points *continued*

Attic scuttle

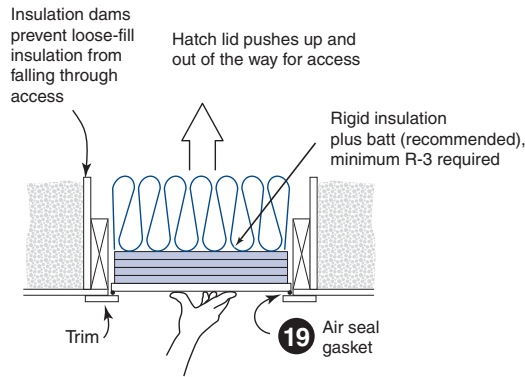

Attic pull-down stairs

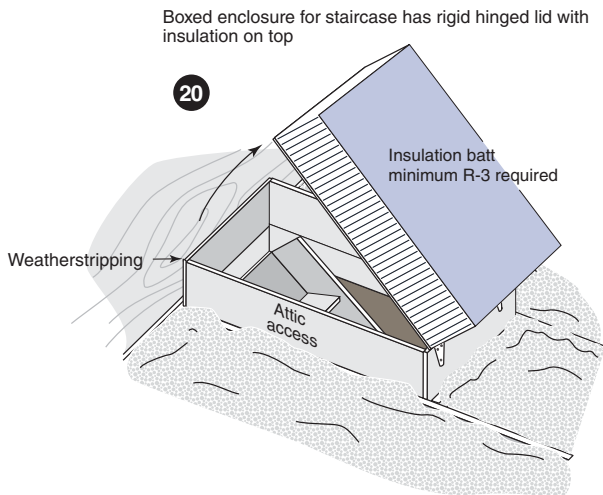
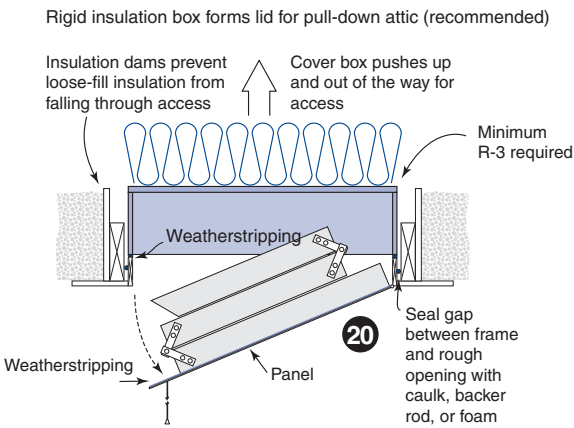

Attic pull-down stairs

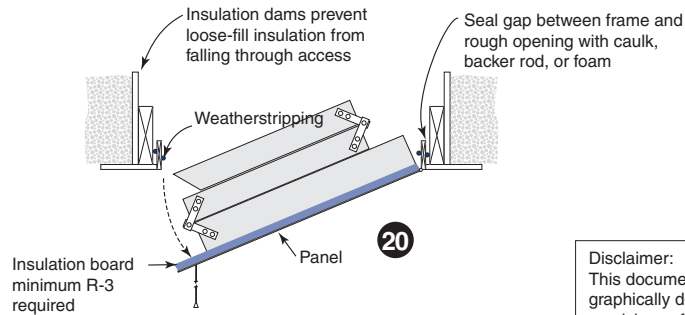

Disclaimer:
This document is intended solely to help graphically demonstrate the air leakage provisions of section 402.4 of the 2006 IECC. It does not cover all airsealing locations or techniques. Other code provisions may be applicable as well.

Air sealing key points *continued*

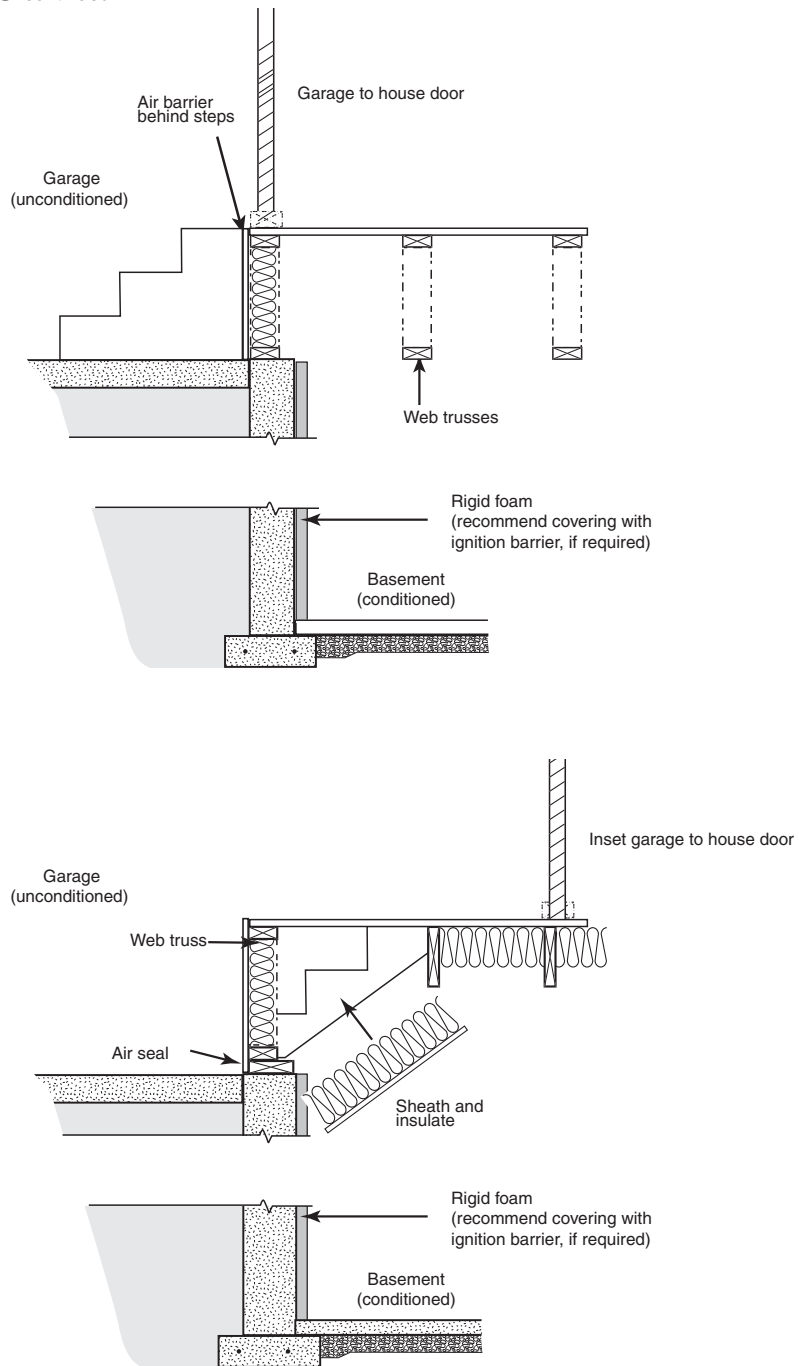

Disclaimer:
This document is intended solely to help graphically demonstrate the air leakage provisions of section 402.4 of the 2006 IECC. It does not cover all airsealing locations or techniques. Other code provisions may be applicable as well.